

Stability Analysis and Compensation of Time Delays in Analog Control Systems

Andri Mirzal

Faculty of Computer Science and Information Systems,
Universiti Teknologi Malaysia
andrimirzal@utm.my

Abstract

Time delays, also known as transport lag, dead time or time lag, are components that hold signal flow off inside the systems. They arise in physical, chemical, biological and economic systems, as well as in the processes of measurement and computation. Time delays can be approximated using polynomial series to allow the systems be analyzed in the same manner as the non time-delay systems. In this paper, we study the influences of delay components to system's stability, derive the Nyquist stability criterion for time-delay systems and use it to analyze stability of the systems, and utilize some polynomial series to approximate the delays and examine their performances. Moreover we study PID controller as delay compensation scheme using two tuning methods: the "iterative method" and Ziegler-Nichols method.

Keywords: delay compensation, Nyquist stability criterion, PID controller, stability analysis, tuning methods, Ziegler-Nichols method

1. Introduction

Time delay in a control system can be defined as time interval between an event started in one point and its output in another point within the system [1]. Delays always reduce stability of *minimum phase systems* (systems that do not have poles or zeros in the right-hand side of s -plane or do not have other delay component) [1]. So that it is important to analyze system's stability under the presence of delays. Delays can be caused by, e.g., transportation and communication lag, sensor response delay in control systems, time to generate control signals, and system parameters approximation using *First Order Lag plus Time Delay* [2].

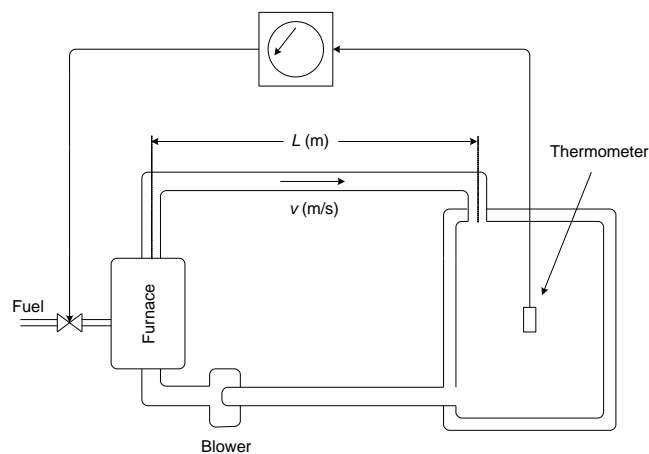

Figure 1. Delay Caused by Mass Flow in a Heat Transfer System

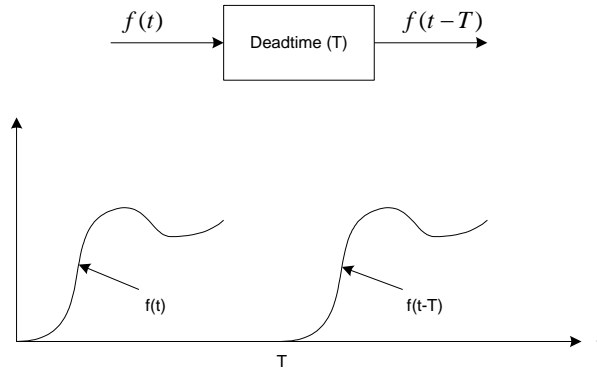

Figure 2. Delay Component in a System

Figure 2 shows delay influence in the system response. As shown, the delay creates time lag in the response which is usually not desirable. The relationship between $f(t)$ and $f(t-T)$ can be written as:

$$\ell[f(t-T)u(t-T)] = \int_0^{\infty} f(t-T)u(t-T)e^{-st} dt$$

with $u(t)$ denotes unit step (the testing signal), e^{-st} denotes the delay component, $\ell[f(t)]$ denotes the Laplace transform of $f(t)$, and s denotes the complex plane. Replacing t with $\tau = t-T$,

$$\int_0^{\infty} f(t-T)u(t-T)e^{-st} dt = \int_{-T}^{\infty} f(\tau)u(\tau)e^{-s(\tau+T)} d\tau.$$

Assume that $f(t) = 0$ for $t < 0$, then,

$$\begin{aligned} \int_{-T}^{\infty} f(\tau)u(\tau)e^{-s(\tau+T)} d\tau &= \int_0^{\infty} f(\tau)u(\tau)e^{-s(\tau+T)} d\tau = \int_0^{\infty} f(\tau)e^{-s\tau} e^{-Ts} d\tau \\ &= e^{-Ts} \int_0^{\infty} f(\tau)e^{-s\tau} d\tau = e^{-Ts} F(s) \end{aligned}$$

so that,

$$\ell[f(t-T)u(t-T)] = e^{-Ts} F(s) = e^{-Ts} \ell[f(t)u(t)]$$

In complex frequency domain, this relationship can be described with the following figure.

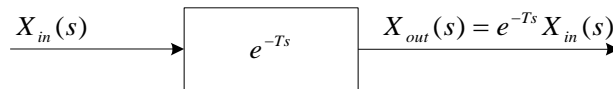

Figure 3. Delay in Frequency Domain

2. Delay Configurations

In a control system, delay components can be found in controlled plant, sensor that measures the output, and/or other parts of the system. In this paper, we assume that the time-delay system can be modeled using the following structure.

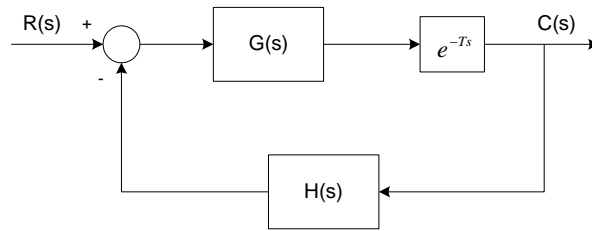

Figure 4. Delay Configuration of Interest

There are other possible configurations; the most common ones are delay at system's feedback, system's input, and system's output. The following figures depict these configurations.

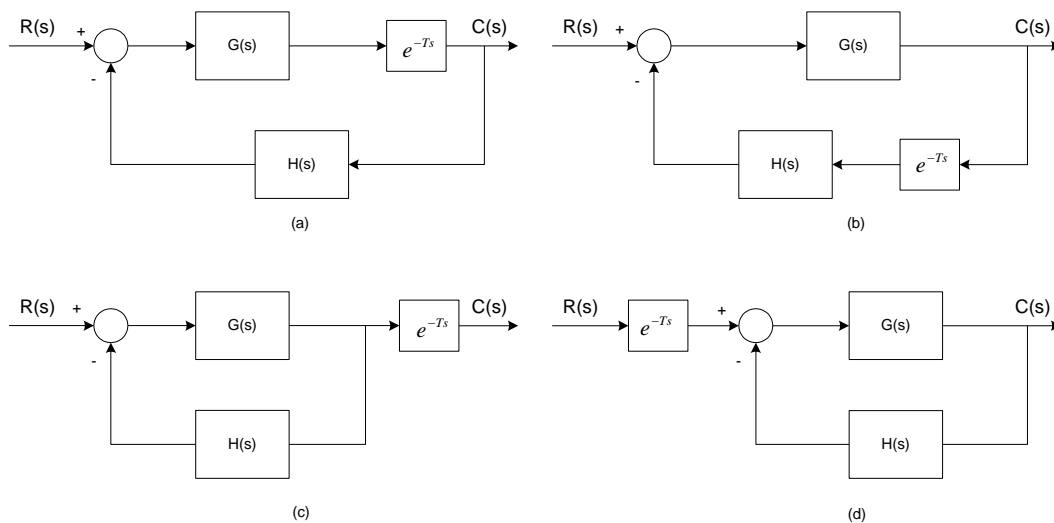

Figure 5. Delay Configurations in Control Systems

For configuration 5(c) and 5(d), the delay components are not in the closed loop, so they won't affect system's stability. They will only shift the output/input without changing the control signal nor the system response. For configuration 5(b), since we can transform it into the following equivalent configuration,

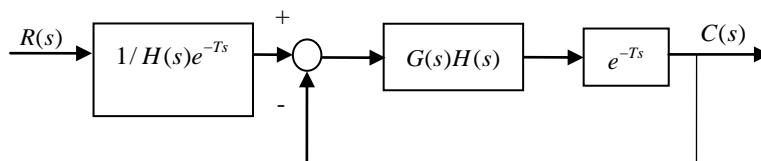

Figure 6. Equivalent Configuration for 5(b)

then, the delay configuration inside the loop is similar to the configuration in Figure 5(a). Consequently, for stability analysis it suffices to consider the system in Figure 4.

3. The Nyquist Stability Criterion for System with Time-delay

The Nyquist stability criterion allows us to do absolute and relative stability analysis for closed loop systems using the corresponding *open loop frequency responses* [3]. This criterion is based on Cauchy integral theorem on complex domain, residual theorem, and mapping theorem [3]. In this section, the Nyquist criterion for time-delay system will be derived.

First let consider a standard closed loop system without time delay with following transfer function (the system as in Figure 4 with delay component removed),

$$\frac{C(s)}{R(s)} = \frac{G(s)}{1 + G(s)H(s)}.$$

Then, the Nyquist criterion for this system can be stated with:

$$Z = N + P,$$

where Z denotes the number of zeros of $1+G(s)H(s)$ on the right hand part of the s -plane, N denotes the number of locus of $G(j\omega)H(j\omega)$ that encircles point $-1+j0$ clockwise, and P denotes the number of poles of $G(s)H(s)$ on the right hand part of the s -plane. The characteristic equation of the system can be written as:

$$F(s) = 1 + G(s)H(s)e^{-sT} = 0.$$

Let define $D(s)$ with

$$D(s) = F(s) - 1 = G(s)H(s)e^{-sT} = 0$$

Cauchy theorem states that contour integral of $D(s)$ along closed path on the s -plane equals to null if $D(s)$ is analytic both inside and along the path.

$$\oint_C D(s)ds = 0$$

with the integral is conducted clockwise. Suppose that $D(s)$ can be decomposed into the following equation (this is a very reasonable assumption since we simply restated $D(s)$ in term of its zeros and poles):

$$D(s) = \frac{(s + z_1)^{k_1} (s + z_2)^{k_2} \dots}{(s + p_1)^{m_1} (s + p_2)^{m_2} \dots} e^{-sT}.$$

Then, the ratio of $D'(s)/D(s)$ can be written as:

$$\frac{D'(s)}{D(s)} = \left(\frac{k_1}{s + z_1} + \frac{k_2}{s + z_2} + \dots \right) - \left(\frac{m_1}{s + p_1} + \frac{m_2}{s + p_2} + \dots \right) - T.$$

Using residual theorem,

$$\oint_C \frac{D'(s)}{D(s)} = -2\pi j [(k_1 + k_2 + \dots) - (m_1 + m_2 + \dots)] = -2\pi j (Z - P)$$

with Z and P denote the number of zeros and poles of $D(s)$ inside the path respectively. Because $D(s)$ is a complex variable, it can be rewritten as:

$$D(s) = |D(s)|e^{j\theta} \text{ and } \ln D(s) = \ln|D(s)| + j\theta,$$

so that,

$$\frac{D'(s)}{D(s)} = \frac{d \ln D(s)}{ds} = \frac{d \ln |D(s)|}{ds} + j \frac{d\theta}{ds},$$

hence,

$$\oint_C \frac{D'(s)}{D(s)} ds = \oint_C d \ln |D(s)| + j \oint_C d\theta = 2\pi j(P - Z).$$

Note that $\oint_C d \ln |D(s)| = 0$ because $\ln |D(s)|$ has an equal value on the initial and the end point of the integration. Accordingly,

$$\frac{\theta_2 - \theta_1}{2\pi} = P - Z.$$

The angular difference between end point and initial point of θ equals to the total change in the phase angle of $D'(s)/D(s)$. As N denotes the number of closed paths on $D(s)$ plane that clockwise encircle the original point, and $\theta_2 - \theta_1 = 2\pi k$, $k = 0, 1, \dots$, then,

$$\frac{\theta_2 - \theta_1}{2\pi} = -N,$$

and

$$N = Z - P.$$

As shown, the existence of delay in the system doesn't change the Nyquist stability criterion, and thus it can be used to analyze the stability of time-delay systems similarly.

In polar plot (Nyquist plot), delay component forms a unit circle in the s -plane.

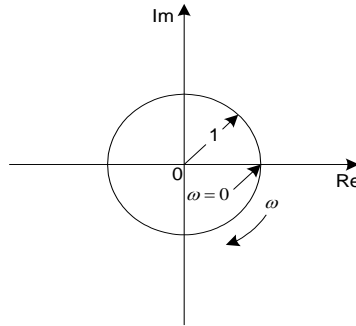

Figure 7. Nyquist Plot for Delay Component

4. Stability Analysis of System with Time-delay

The stability of closed loop system is a fundamental concept in system engineering since only this kind of system has practical use [4]. A stable system is defined as the system that will produce bounded outputs if given bounded inputs [5]. The stability of a *linear time invariant system* (the most commonly used model for control systems) can be determined by examining the roots of its transfer function. A system is stable if every root has a negative real part, unstable if there exists at least one root that has

positive real part, and marginally stable if all roots lie on imaginary axis on the complex plane.

In this section, the stability analysis of time-delay system in the frequency domain using the Nyquist criterion will be presented. There are some benefits of analyzing system's stability in frequency domain. First, in general the stability tests are simple and the accuracy can be improved using sinusoidal signal generator. Second, complex transfer functions can be obtained experimentally using frequency response tests. And third, noise effects can be ignored so that analysis and design process can be extended to nonlinear systems [2].

In frequency domain, magnitude and phase angle of delay can be written as:

$$|G(\omega)| = |\cos \omega T - j \sin \omega T| = 1$$

$$\angle G(\omega) = -\omega T$$

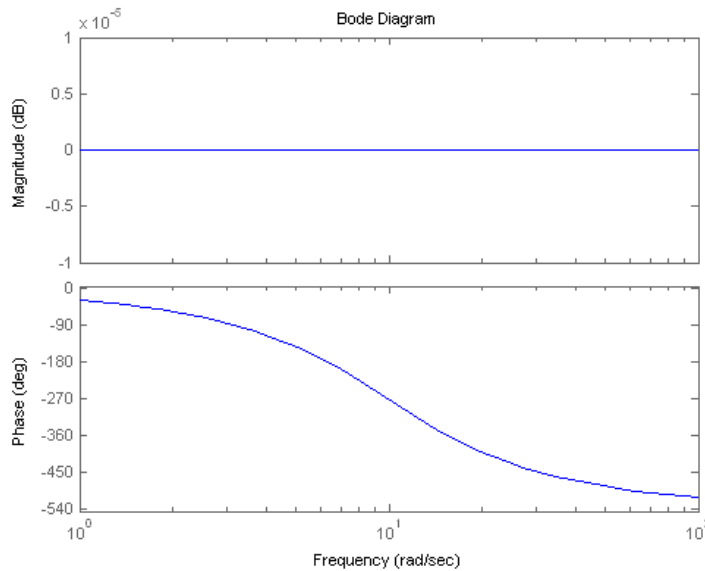

Figure 8. Bode Plot for Delay Component with $T = 0.5$

As shown in Figure 8, the delay component doesn't contribute to magnitude of the system response, but can create large response lag in high frequencies.

In analyzing system's stability using the Nyquist criterion, the following cases can happen:

1. If $-1+j0$ is not encircled by the closed path on $G(s)H(s)$ plane, then the system is stable if there is no pole of $G(s)H(s)$ on the right hand side of the s -plane.
2. If $-1+j0$ is encircled counter-clockwise by the closed path on $G(s)H(s)$ plane, then the system is stable if the number of closed paths that encircle the point equals to the number of poles of $G(s)H(s)$ on the right hand side of the s -plane.
3. If $-1+j0$ is encircled clockwise by the closed path on $G(s)H(s)$ plane, then the system is not stable.

One important concept in stability analysis is the relative stability. The relative stability is related to the *settling time*. A system with a faster settling time is more stable than the system with a slower settling time. The Nyquist plot can also be used to determine the degree of the stability. Since every system with non-unity feedback can be transformed into the corresponding equivalent system with unity feedback (see fig. 6 for an example), it suffices to discuss systems with unity feedback ($H(s) = 1$).

One of the most important things in analyzing system's stability is to locate all poles of the *closed loop transfer function*; or at least poles that are near to $j\omega$ axis (usually these are a pair of dominant poles). Figure 9 depicts the conformal mapping from s -plane to $G(s)$ plane when delay doesn't exist.

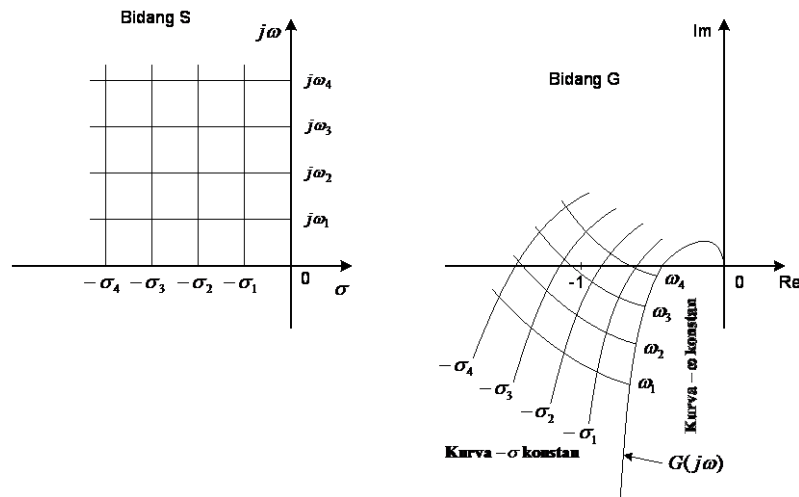

Figure 9. Conformal Mapping from s-plane to $G(s)$ Plane

In general, the nearer the $G(j\omega)$ locus to $-1+j0$, the larger the *maximum overshoot* and the slower the settling time, and thus the less stable the system is. And when $G(j\omega)$ locus passes through $-1+j0$, the system is in the border of stable and unstable condition.

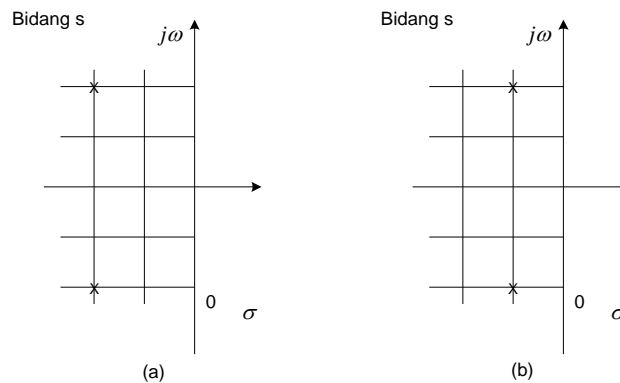

Figure 10. Two Systems Each with a Pair of Closed Loop Complex Poles Depicted by \times

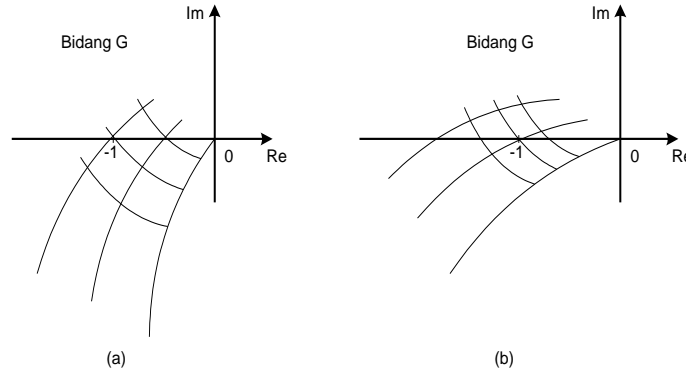

Figure 11. The Corresponding Conformal Mappings for Systems in Figure 10

Figure 10 shows two systems with poles depicted on the s -plane. Since system 10(a) has more negative real parts than system 10(b), it will settle faster. Thus, system 10(a) is more stable than system 10(b). This fact can also be observed from their conformal mappings in Figure 11. As shown, the $G(j\omega)$ locus of system 11(b) is closer to $-1+j0$ than 11(a), then it is less stable than system 11(a).

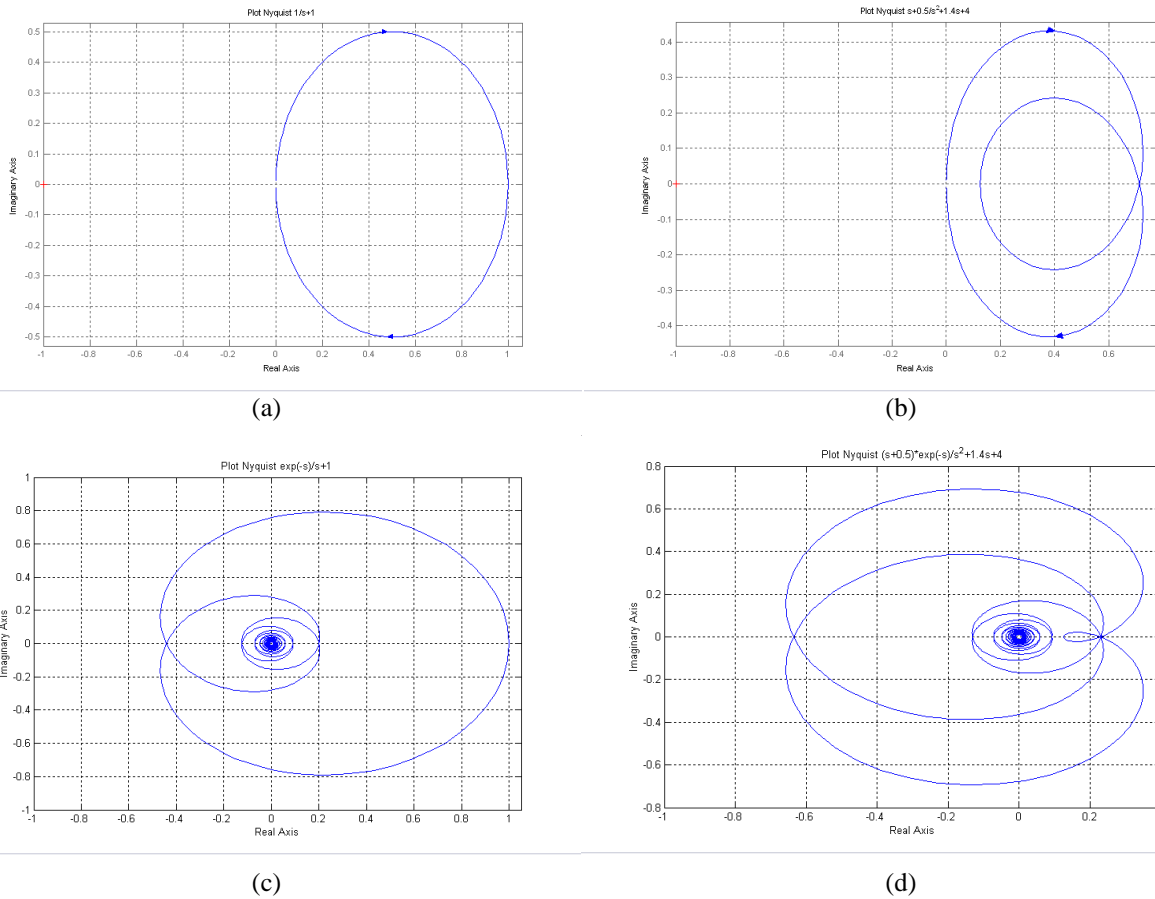

Figure 12. Nyquist Plots; (a) Plot for the First Order System, (b) Plot for the Second Order, (c) and (d) are the Plots when the Delay Components are Added into the Corresponding Systems

Now we will show how the delay component reduces system's stability using examples. The first is a first order system with *open loop transfer function* (OLTF) defined as:

$$G(s)H(s) = \frac{1}{s+1},$$

and the second is a second order system with OLTF defined as:

$$G(s)H(s) = \frac{s+0.5}{s^2+1.4s+4}.$$

Both systems are absolutely stable since there is neither zero nor pole lies on the right hand side of the s -plane and locus of $G(j\omega)H(j\omega)$ do not encircle $-1+j0$. Fig. 12(a) and 12(b) show the Nyquist plots for the first and second order system respectively, and fig. 12(c) and 12(d) show the plots when the delay components are added into the systems. As shown, in each time-delay systems, the delay component make $G(j\omega)H(j\omega)$ locus nearer to $-1+j0$ than the original systems, consequently the time-delay systems become less stable.

The relative stability based on the distance of $G(j\omega)$ locus to $-1+j0$ point can be stated in the phase margin. The phase margin is defined as the phase lag that needs to be compensated for the system to be at the border of stability. Mathematically, the phase margin can be written as:

$$\gamma = 180^\circ + \phi$$

where γ denotes the phase margin and ϕ denotes the phase of system's OLTF at *gain crossover frequency*. For time-delay system, the phase margin can be written as:

$$\gamma = 180^\circ + \phi - \omega_g T$$

where ω_g denotes gain crossover frequency and T denotes the delay time. As shown, time-delay system creates larger phase lag, so it is less stable than the original system.

5. Delay Approximation using Polynomial Series

Delay approximation using polynomial series is a common technique in control systems study. The approximation allows methods for analyzing non time-delay systems can be used without or with minor modifications. In some methods like Routh-Hurwitz stability criterion and root locus analysis, the approximation cannot be avoided. Moreover, the use of computer requires the delay to be approximated using polynomial series. The approximation will inevitably generate errors which depend on the type and the order of the series. In some cases where high accuracy is not required or the system has large delay compared to its settling time, using low order series is usually sufficient. In this paper, seven polynomial series that are commonly used in approximating delays will be discussed. Table 1 gives formulations of these series, and Table 2 shows poles and zeros added to the system when the series are used to approximate the delay.

Table 1. Delay Approximation using Second-order Polynomial Series [1]

Taylor series	$e^{-s\tau} \approx 1 - s\tau + 0.5s^2\tau^2$
Pade series	$e^{-s\tau} \approx \frac{1 - 0.5s\tau + 0.0833s^2\tau^2}{1 + 0.5s\tau + 0.0833s^2\tau^2}$
Marshall series	$e^{-s\tau} \approx \frac{1 - 0.0625s^2\tau^2}{1 + 0.0625s^2\tau^2}$
Product series	$e^{-s\tau} \approx \frac{1 - 0.5s\tau + 0.125s^2\tau^2}{1 + 0.5s\tau + 0.125s^2\tau^2}$
Laguerre series	$e^{-s\tau} \approx \frac{1 - 0.5s\tau + 0.0625s^2\tau^2}{1 + 0.5s\tau + 0.0625s^2\tau^2}$
Paynter series	$e^{-s\tau} \approx \frac{1}{1 + s\tau + 0.4054s^2\tau^2}$
Direct Frequency Response	$e^{-s\tau} \approx \frac{1 - 0.49s\tau + 0.0954s^2\tau^2}{1 + 0.49s\tau + 0.0954s^2\tau^2}$

Table 2. Poles and Zeros of the Series

Series	Poles	Zeros
Taylor	-	$1 + j1$ and $1 - j1$
Pade	$-3.0012 + j1.7314$ and $-3.0012 - j1.7314$	$3.0012 + j1.7314$ and $3.0012 - j1.7314$
Marshall	$j4$ and $-j4$	4 and -4
Product	$-2 + j2$ and $-2 - j2$	$2 + j2$ and $2 - j2$
Laguerre	4 and -4	4 and 4
Paynter	$-1.2333 + j0.9724$ and $-1.2333 - j0.9724$	-
DFR	$-2.5681 + j1.9715$ and $-2.5681 - j1.9715$	$2.5681 + j1.9715$ and $2.5681 - j1.9715$

To evaluate performances of the series, we study three cases of first order, second order, and third order systems with unit step input. Figures 13–15 show the systems. Because most of industrial processes can be modeled into first order system with time delay, our analysis will cover many cases in real applications. We define the error rates with the following equation:

$$E_{step} = \frac{\int_{t_0}^{t_1} |c(t) - \overline{c(t)}| dt}{(t_1 - t_0)}$$

where $c(t)$ denotes output and $\overline{c(t)}$ denotes output with delay approximated by series. Tables 3–5 show the approximation errors for the systems in Figures 13–15. Note that the delays are in second.

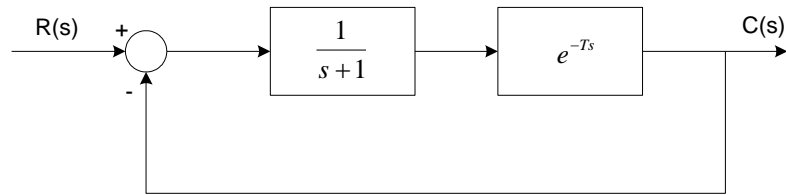

Figure 13. First Order System with Time Delay

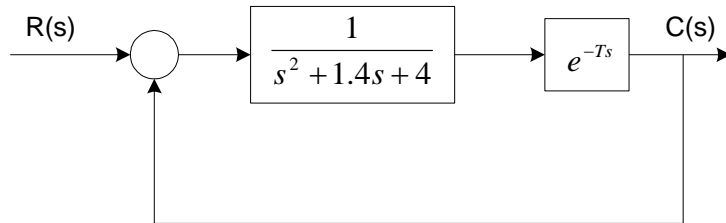

Figure 14. Second Order System with Time Delay

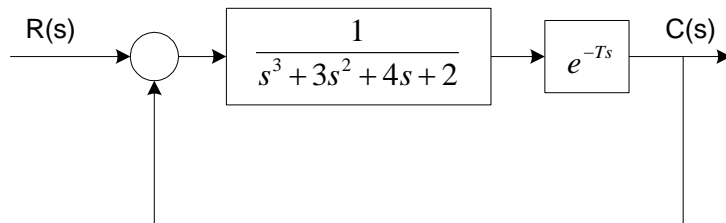

Figure 15. Third Order System with Time Delay

Table 3. Delay Approximation Errors in the First Order System

Delay	Taylor	Pade	Marshall	Product	Laguerre	Paynter	DFR
0.01	0.4252	0.4242	0.4241	0.4242	0.4242	0.4242	0.4242
0.03	0.4238	0.4228	21.780	0.4228	0.4228	0.4228	0.4228
0.1	0.4196	0.4182	75.63	0.4182	0.4182	0.4184	0.4182
0.3	0.4132	0.4057	213.2	0.4057	0.4060	0.4071	0.4056
1	0.7476	0.3688	271.8	0.3676	0.3740	0.3775	0.3673
3	2.300	0.3140	45.04	0.3228	0.3341	0.3304	0.3097
10	1.516	0.1591	52.38	0.1415	0.2935	0.2729	0.1275
30	0.9368	0.2100	104.3	0.2017	0.3672	0.2489	0.1769

Table 4. Delay Approximation Errors in the Second Order System

Delay	Taylor	Pade	Marshall	Product	Laguerre	Paynter	DFR
0.01	0.0468	0.0468	0.0468	0.0468	0.0468	0.0466	0.0468
0.03	0.0466	0.0466	0.0469	0.0466	0.0466	0.0466	0.0466
0.1	0.0460	0.0460	0.0481	0.0460	0.0460	0.0460	0.0460
0.3	0.0450	0.0444	0.0539	0.0445	0.0444	0.0450	0.0444
1	0.1106	0.0401	0.4187	0.0399	0.0424	0.0580	0.0395
3	1.4262	0.0604	3.7052	0.0472	0.0538	0.0515	0.0452
10	1.4133	0.0550	0.5250	0.0457	0.0674	0.0637	0.0492
30	1.1482	0.0677	0.4379	0.0604	0.0800	0.1736	0.0630

Table 5. Delay Approximation Errors in the Third Order System

Delay	Taylor	Pade	Marshall	Product	Laguerre	Paynter	DFR
0.01	0.1109	0.1109	0.1108	0.1109	0.1109	0.1109	0.1108
0.03	0.1104	0.1104	0.1106	0.1106	0.1104	0.1104	0.1104
0.1	0.1089	0.1089	0.1109	0.1089	0.1089	0.1089	0.1088
0.3	0.1048	0.1046	0.1147	0.1047	0.1046	0.1050	0.1046
1	0.09794	0.09181	0.1364	0.09265	0.09261	0.1294	0.09192
3	0.2701	0.0864	1.045	0.06048	0.1031	0.08456	0.06379
10	0.7653	0.05599	1.564	0.06279	0.07596	0.1057	0.05602
30	1.012	0.1060	1.584	0.09923	0.1364	0.1152	0.09788

Table 6. Average Errors for All Cases

Series	Order one	Order two	Order three	Average
Taylor	0.898	0.535	0.323	0.585
Pade	0.340	0.0509	0.0969	0.163
Marshall	98.1	0.660	0.597	33.1
Product	0.338	0.0471	0.0938	0.160
Laguerre	0.380	0.0534	0.105	0.180
Paynter	0.363	0.0664	0.109	0.179
DFR	0.332	0.0476	0.0930	0.157

As shown in Table 6, DFR (Direct Frequency Response) series gives the minimum average errors for order one and order three. In case of order two, Product series gives the minimum errors and DFR is the second. However, the differences between these two series are very small. Furthermore, DFR series has the minimum average errors for all three cases. So, it can be concluded that DFR series has the best performance among the seven series.

If we investigate the error plots as shown in Figure 16–18, we can find interesting patterns in which there is a breaking point for each order two and three case (0.3 second for order two and 1 second for order three). If delay is smaller than the delay at the breaking point, all seven series give almost the same error rates. And if the delay is bigger than this value, the error rates will diverge. In case of order one, however, such a common breaking point does not exist; Marshall series diverges immediately after leaving the first point at delay 0.01 second, following by Taylor series at 0.3 second. But at delay 3 second we can see such a breaking point at which the other series diverges. Additionally, in all cases the series give relatively the same error rates except for Marshall and Taylor series.

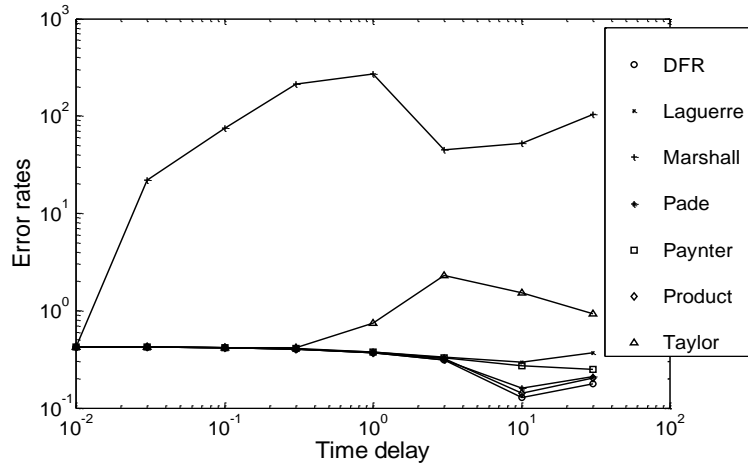

Figure 16. Error Rates of Polynomial Series for System in Figure 13

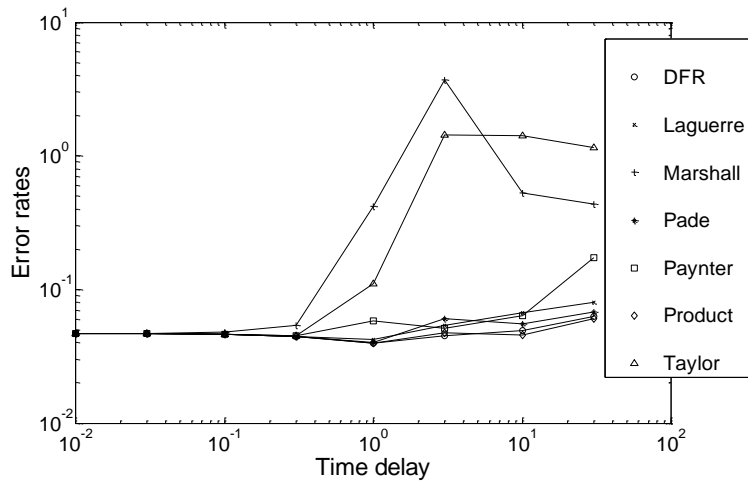

Figure 17. Error Rates of Polynomial Series for System in Figure 14

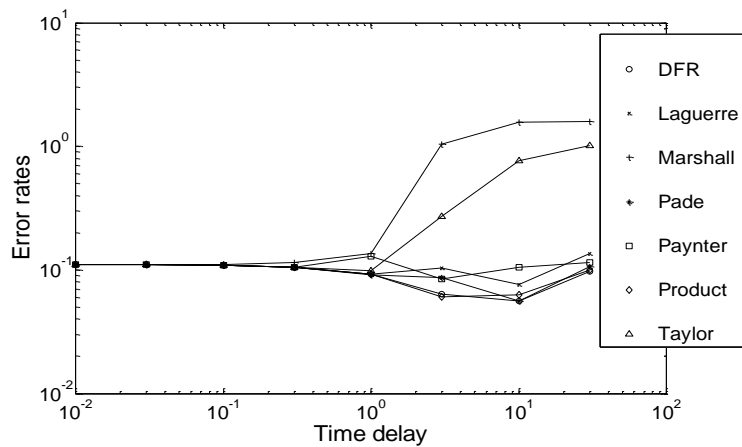

Figure 18. Error Rates of Polynomial Series for System in Figure 15

6. PID Controllers

PID controllers are the main controllers in industries (more than 90% [5]). It has high level of robustness, and is easy to operate and understand because of the structural simplicity. A PID controller can be used to improve the stability of time-delay systems because it can increase *stability margin* and reduce *%overshoot* and settling time (ST). However, there are some limitations that should be mention: (1) it is only reliable for delay smaller than *process time constant*, (2) it is sensitive to noise, and (3) it is not suitable for nonlinear interactive models [1].

Here, we will use a PID controller to improve stability of a system with time delay. The system under consideration is assumed to have been modeled by order one with time delay. Because most of higher order systems in industrial processes can be modeled using this formulation [6], it can be expected that the simulation results are sufficiently descriptive for real cases. The following equation gives such a model:

$$G(s) = \frac{Ke^{-s\tau}}{1+sT}$$

We will analyze the capability of the PID controller in compensating the delays by measuring some system performance parameters, i.e., stability margins (**SM**), %overshoots (**%Ov**), settling times (**ST**), and *error signals* (**ES**). As the tuning methods, iterative method and Ziegler-Nichols method will be used. The following figure shows the schematic of the PID controller and plant with $G_p(s) = 1/(1+sT_p)$ and for simulation, we set process time constant $T_p = 1$ second. Table 7 shows the system performances without PID controller to compensate the influence of delay component to system's stability.

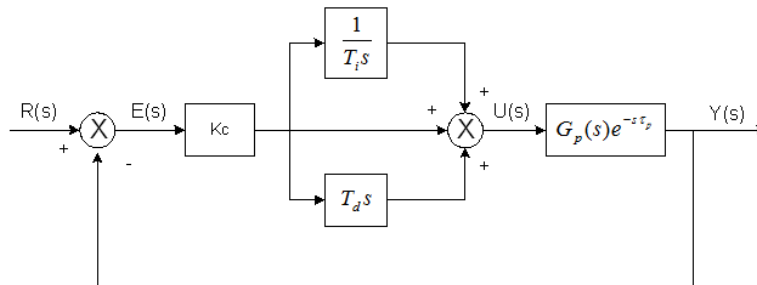

Figure 19. PID Controller General Structure

Table 7. System Performances without PID Controller

Delay	SM	%Ov	ST	ES
0.01	7.2	0	1.45	0.5
0.025	0.7	0	1.44	0.5
0.05	7.8	0	1.44	0.5
0.075	9.3	0	1.43	0.5
0.1	11.5	0	1.41	0.5
0.25	7.8	0	1.29	0.5
0.5	4	8.62	2.06	0.5
0.75	2.8	24.3	3.66	0.5
1	2.2	38	4.88	0.5
Av.	5.92	7.88	2.12	0.5

6.1. Iterative Method

Iterative method is the standard method in tuning PID parameters. If the system can be characterized by a simple model, then graphical approaches like root locus and Bode plot can be utilized to assist the tuning process. The following gives the iterative method steps.

1. Set T_d to the minimum value and T_i to the maximum value.
2. Set K_c to a low value, and put the system under automatic state.
3. Increase K_c until the system outputs sinusoidal signal, then set K_c to half of this value.
4. Decrease T_i until the sinusoidal signal observed, then set T_i to three times of this value.
5. Increase T_d until sinusoidal signal observed, then set T_d to one-third of this value.

Table 8 shows the improvements obtained using the iterative method. By comparing Table 8 with Table 7, the iterative method brings significant improvements in all system performance parameters in average. Stability margin improves more than three times, %overshoot reduces half, and settling time reduces more than 20%. And the most visible improvement is the error signal where as shown in Table 8, 9 and 10, there is no longer error signal in the system with PID controller.

Table 8. System Performances with Iterative Method (three times)

Delay	K	T_i	T_d	SM	% Ov	ST	ES
0.010	3.90	0.210	0.0177	38.8	27.8	1.02	0
0.025	3.29	0.255	0.0277	5.40	26.7	1.23	0
0.050	3.83	0.240	0.0230	6.26	32.5	1.08	0
0.075	4.56	0.234	0.0207	7.72	48.4	1.29	0
0.10	5.65	0.330	0.0183	9.35	51.1	0.833	0
0.25	3.95	0.876	0.108	8.49	9.90	0.680	0
0.50	2.00	1.35	0.200	4.30	10.0	2.40	0
0.75	1.43	1.74	0.243	3.00	4.50	3.45	0
1.0	0.500	1.98	0.283	2.40	2.56	4.71	0
Av.				9.52	23.7	1.85	0

Table 9. System Performances after Retuning

Delay	K	T_i	T_d	SM	% Ov	ST	ES	G
0.010	3.90	0.90	0.0100	64.7	0.700	0.590	0	12.57
0.025	3.29	1.00	0.0200	30.3	0.00	0.820	0	3.120
0.050	3.83	1.00	0.0200	25.0	0.00	0.660	0	11.50
0.075	4.56	1.00	0.0180	16.5	0.50	0.330	0	2.010
0.10	5.65	1.50	0.0200	13.7	6.20	0.770	0	2.010
0.25	3.95	0.876	0.108	8.49	9.90	0.680	0	1.000
0.50	2.00	1.35	0.200	4.30	10.0	2.40	0	2.030
0.75	1.43	1.74	0.243	3.00	4.50	3.45	0	2.090
1.0	1.05	1.98	0.283	2.40	2.56	4.71	0	2.110
Av.				18.7	3.82	1.60	0	

To further improve the performance of the PID controller, it is common to retune the values of T_i and T_d . In general, if T_i increases then %overshoot will reduce and settling time will increase, and if T_d reduces then %overshoot will increase and settling time will reduce. In retuning, we increased T_i and reduced T_d . Table 9 gives the results of the retuning process

with G denotes the amplitude of steady state response when gain is set to the stability margin. As shown, in average the retuning improves the system performances significantly as stability margin increases more than twofold, %overshoot reduces more than six times and settling time reduces slightly. However, the iterative method that based on trial and error has several drawbacks, e.g., it takes considerable time to tune the parameters, it requires the system to be in the border of stability in order to tune the parameters, and it cannot be used to design compensator for systems that are not open-loop stable [7].

6.2. Ziegler-Nichols Method

When the system cannot be represented using simple model, then the iterative method can no longer be used. In this case, Ziegler-Nichols method is used instead [3]. This method was introduced by Ziegler and Nichols for single input single output process that can be represented using first order with time delay model. The benefit of this simple tuning method is it needs only a single test to determine the PID parameters so that there is no trial and error procedure as in the iterative method. The following gives the Ziegler-Nichols tuning method:

1. Remove integral and derivative action. Set T_i to its largest value and set T_d to zero.
2. Create a small disturbance in the loop by changing the set point. Adjust the proportional gain until the oscillations have constant amplitude.
3. Record the gain value (K_{cr}) and period of oscillation (P_{cr}).
4. Set K_c to $K_{cr}/1.7$, T_i to $P_{cr}/2$, and T_d to $P_{cr}/8$.

Table 10 shows the tuning results using Ziegler-Nichols method. Note that at delay 0.075 and 0.10 second settling times can't be measured because system responses are oscillating. This can also be observed from stability margin values that are smaller than K_p . If we compare these results with iterative method, then in general Ziegler-Nichols method produced smaller stability margins and bigger %overshoots. This implies that Ziegler-Nichols method produces less stable system and takes more time to settle than the system produced by the iterative method.

Table 10. System Performances with Ziegler-Nichols Method

Delay	K_{cr}	P_{cr}	K_p	T_i	T_d	SM	% Ov	ST	ES	G
0.01	6.08	0.4	3.65	0.2	0.05	14.4	28.46	1.12	0	6.33
0.025	6.59	0.4	3.95	0.2	0.05	13.7	31.08	1.03	0	1.78
0.05	7.66	0.4	4.6	0.2	0.05	9	42.94	1.18	0	1.04
0.075	9.12	0.4	5.47	0.2	0.05	5.3	39.5	-	-	1.03
0.1	11.3	0.4	6.78	0.2	0.05	6.32	44.72	-	-	1.05
0.25	7.9	1	4.74	0.5	0.125	7.43	36.61	1.34	0	3.68
0.5	4	1.7	2.4	0.85	0.213	4.33	37.47	2.57	0	2.13
0.75	2.84	2.4	1.72	1.2	0.3	2.87	34.07	3.68	0	2
1	2.3	3.08	1.38	1.5	0.385	2.25	31.48	4.71	0	2
Av.						7.29	36.26	2.23	0	

7. Conclusions

Delay components are always present in the control systems as it takes time for the control signal to flow from one point to another point within the systems. The main concern in this paper is the influence of the delays to system's stability. As only delays that are located inside the system's closed loop can affect system's stability, it suffices

to analyze system with time delay as shown in Figure 4. By using the Nyquist stability criterion and the Bode plot, it is shown that delay always reduces stability of minimum phase systems. This fact can also be shown by using the conformal mapping from s -plane to $G(s)$ plane or phase margin concept.

There are some cases in which delay component must be approximated using polynomial series. In this paper, seven commonly used series are utilized and numerical results showed that the DFR series has the best overall performances among the other series in the analyzed cases. There is also a common breaking point for each the order two and order three cases such that if time delay is smaller than this value all seven series give relatively the same error rates, and if bigger than this value the error rates will diverge. In the order one case, however, such a common breaking point is not observed.

PID controller parameters optimization using the iterative method can improve the stability of the time-delay system significantly. Compared to the uncompensated system, in average it improves stability margin more than three-fold, %overshoot more than two-fold, settling time more than 30%, and eliminates error signals completely. Moreover, this method also confidently outperformed the Ziegler-Nichols method in tuning the PID parameters.

References

- [1] A. O' Dwyer, "The Estimation and Compensation of Processes with Time Delays", Ph.D. Thesis, School of Electronic Engineering, Dublin City University, (1996).
- [2] G. F. Franklin, J. D. Powell and A. Emami-Naeni, "Feedback Control of Dynamic Systems", 3rd edition, Addison-Wesley Publishing Company, (1994).
- [3] K. Ogata, "Modern Control Engineering", 5th edition, Prentice-Hall, (2009).
- [4] R. C. Dorf and R. H. Bishop, "Modern Control System", 12th ed., Prentice-Hall, (2010).
- [5] A. O' Dwyer, "Estimation of model parameters (including time delay) in a Smith Predictor structure", Technical Report No: AOD.98.04, Dublin Institute of Technology, (1998).
- [6] D. Chen and D. E. Seborg, "PI/PID Controller Design Based on Direct Synthesis and Disturbance Rejection", Industrial and Engineering Chemistry Research, vol. 41, no. 19, (2002), pp. 4807–4822.
- [7] W. K. Ho, C. C. Hang and J. H. Zhou, "Performance and gain and phase margins of well-known PI tuning formulas", IEEE Transactions on Control Systems Technology, vol. 4, no. 4, (1995), pp. 473–477.

Author



Andri Mirzal received PhD and MSc in Information Science and Technology from Hokkaido University, and Bachelor of Engineering in Electrical Engineering from Institut Teknologi Bandung. His research interests include Machine Learning, Computational Intelligence, Optimization Methods, Web Search Engine, and Linear Inverse Problems. He was also a recipient of Monbukagakusho Scholarship and a fellow of Asian Youth Fellowship Program. Currently, he is a Senior Lecturer at Faculty of Computer Science and Information Systems, Universiti Teknologi Malaysia.

